

GD 1600

Light Weight Well Stimulation Pump



SPECIFICATIONS

Maximum Input	1600
Maximum RPM	330 RPM
No. of Plungers	3
Stroke Length	8 in. (203 mm)
Plunger Load	200,000 lbs. (90,720 kg)
Pump Weight	8,550 lbs. (3,878 kg)
Gear Ratio	9:1

PLUNGER DIAMETER		DISPLACEMENT PER REVOLUTION		DISPLACEMENT @ PUMP RPM				DISPLACEMENT @ PUMP RPM				DISPLACEMENT @ PUMP RPM				DISPLACEMENT @ PUMP RPM			
				100				150				200				330			
in.	mm.	Gal/Rev.	Liter/Rev.	GPM	LPM	PSI	kg/sq. cm	GPM	LPM	PSI	kg/sq. cm	GPM	LPM	PSI	kg/sq. cm	GPM	LPM	PSI	kg/sq. cm
Forged Steel Autofrettaged High Pressure Valve Over Valve Fluid Ends																			
3.5	89	1.00	3.79	100	379	20700	1455.4	150	569	16400	1153.1	200	758	12300	865	330	1250.7	7400	520
3.75	95	1.15	4.34	115	434	18100	1273	172	651	14300	1009	229	868	10750	756	378	1433	6500	457
Forged Steel Autofrettaged Medium Pressure Valve Over Valve Fluid Ends																			
4.5	114	1.65	6.25	165	625	12600	886	248	938	9950	700	330	1250	7450	524	545	2063	4550	320
5	127	2.04	7.72	204	772	10200	717	306	1158	8050	566	408	1544	6050	425	673	2547	3650	257
5.5	140	2.47	9.34	247	934	8400	591	370	1404	6650	468	493	1868	5000	352	814	3082	3050	214
Forged Steel Autofrettaged Low Pressure Valve Over Valve Fluid Ends																			
5.5	140	2.47	9.34	247	934	8400	591	370	1401	6650	468	493	1868	5000	352	814	3082	3050	214
6	152	2.94	11.11	294	1111	7100	499	440	1667	4400	394	587	2223	4200	295	969	3668	2550	179
6.5	165	3.45	13.04	345	1304	6050	425	517	1957	4800	337	689	2609	3600	253	1137	4304	2150	151
INPUT POWER:		BHP		1350				1600				1600				1600			
		kW		1007				1193				1193				1193			

Ratings are based on 90% mechanical efficiency and 100% volumetric efficiency.

**Gardner
Denver**
Pumping Perfected.™

MATERIAL SPECIFICATIONS

CYLINDER	Forged SAE 4330 steel
PACKING	Adjustable or header ring
STUFFING BOX	Replaceable steel
CRANKSHAFT	Forged steel surface hardened
CONNECTING RODS	Steel hardened surface
CROSSHEADS	High strength 4140 steel
CROSSHEAD SLIDES	High strength steel
TIE RODS	Alloy steel with cold rolled threads
MAIN BEARINGS	Roller
SPHERICAL CROSSHEAD BEARING	Bronze

STANDARD FEATURES

- Gearbox Design
- Crankshaft type construction
- Left or right gear box mounting
- Suction and discharge on either side
- Clamp connections between plungers and extension rods
- Colmonoy plungers
- Cradle cover
- Autofrettaged fluid end cylinder with through stud design
- Forged steel fluid end and plunger sizes ranging from 3.75" to 6.5"
- Replaceable WEICO discharge connections
- 6" suction manifold with Victaulic or flanged connections
- Header-ring style packs
- Standard fluid end tool kit

OPTIONAL FEATURES

- Dual discharge flanges
- Multiple center gauge connections
- Suction stabilizers
- Discharge pulsation dampeners
- Valve seat puller assembly
- Hydraulic torque wrench
- Companion flanges

SPECIFICATIONS

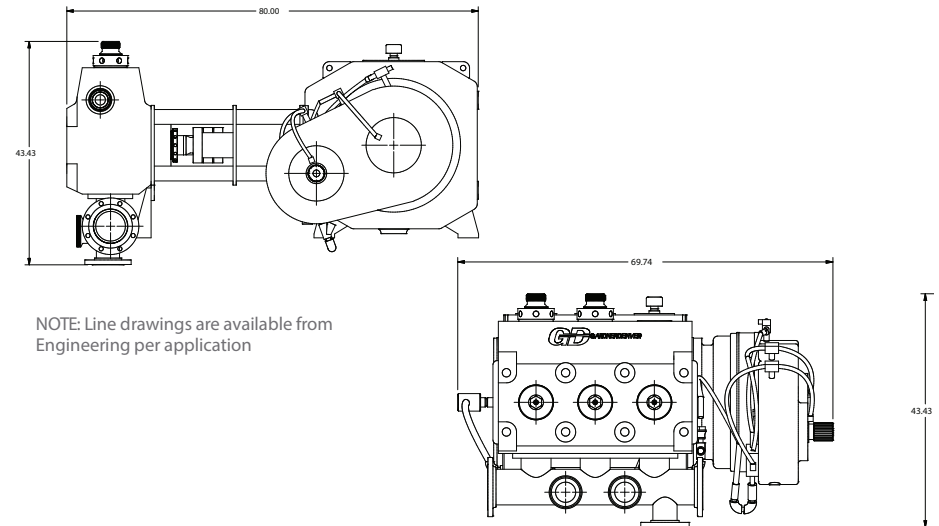

CONNECT WITH US :