

TGE Triplex Well Servicing Pump

WELL SERVICING

165 HP, 5" Stroke for Intermittent Service

ADD- Gardner Denver TGE Well Servicing pumps combine the tried and proven TEE design with a gear reducer for superior service in the oil fields throughout the world.

- Eccentric construction
- Integral planetary gear reduction ration of 5 to 1
- Right or left-hand shaft extension
- Pressure lubrication of power end
- Suction and discharge on either side
- Solid connecting rods
- Clamp type connections between plungers and cross head extensions
- Removable stuffing boxes with threaded glands
- Choice of plungers with non-adjustable type packing or piston liner construction

PERFORMANCE RATINGS – INTERMITTENT SERVICE

PLUNGER/PISTON* SIZE		GALLONS PER REVOLUTION		GALLONS/LITERS PER MINUTE AT THE FOLLOWING RPM																			
				50				100				200				250				300			
in.	mm.	gal.	liters	GPM	LPM	Max PSI	kg/cm ²	GPM	LPM	Max PSI	kg/cm ²	GPM	LPM	Max PSI	kg/cm ²	GPM	LPM	Max PSI	kg/cm ²	GPM	LPM	Max PSI	kg/cm ²
4	102	.817	3.091	41	155	3500	246	82	309	2932	206	163	618	1475	104	204	773	1178	83	245	927	981	69
3.5	89	.623	2.359	31	118	4571	321	62	236	3816	268	125	472	1923	135	156	590	1541	108	187	708	1286	90
3	76	.450	1.741	23	87	6222	438	46	174	5226	368	92	348	2613	184	115	435	2090	147	138	522	1742	123
2.75	70	.380	1.463	19	73	7405	521	38	146	6164	433	76	293	3122	220	95	366	2504	176	114	439	2070	146
2.5	63	.319	1.206	16	60	8960	630	32	121	560	532	64	241	3774	265	80	302	3016	212	96	362	2515	177
2.25	57	.258	.977	13	49	10000	703	26	98	9318	655	52	195	4659	328	65	244	3727	262	77	293	3102	218
2	51	.204	.772	10	39	10000	703	20	77	10000	703	41	154	5892	414	51	193	4714	332	61	232	3928	276
1.75	44	.156	.591	8	30	10000	719	16	59	10000	703	31	118	7705	542	39	148	6164	433	47	177	5125	360

Based on 85% mechanical efficiency and 100% volumetric efficiency.

*Piston and liner construction available in 2 3/4", 3", 3 1/2" and 4" only.

**The duty cycle of a pump rated for intermittent duty is not to exceed 30 minutes at loads above the maximum established for continuous running followed by an equal period at no load.

Note: Use plungers/packing for acid service or pressures in excess of 4,000 PSI. Pistons/liners are not recommended for these applications.

**Gardner
Denver**
Pumping Perfected.™

TGE Triplex Well Servicing Pump

STANDARD FEATURES

- Colmonoy plungers and packing or piston and liner construction
- Hardened steel valves
- Block steel fluid end
- Fabricated suction manifold
- Lubricating oil pump and filter
- Weld neck companion flanges
- Integral 5 to 1 planetary gear reducer

CRANKCASE OIL CAPACITY: 12 gallons (45 liters)

SUCTION OPENING: 6" (152 mm) - Pipe, beveled for welding

DISCHARGE CONNECTION: 2 9/16" (66 mm) weld neck API 10,000# PSI

OPTIONAL FEATURES

- Mechanical lubricator for plunger stuffing box packing
- Suction and discharge surge chambers
- Relief valve
- Fabricated steel skid and motor or engine
- Fabricated skid under pump only
- Integral 6.25 to 1 planetary gear reducer
- Plunger rod washing system (mounted only on unitized packages)

LENGTH: 69.8" (1773mm)

HEIGHT: 26.8" (681mm)

WEIGHT: Dry, less optional skid: 3,200 lbs (1,451 kg)

SPECIFICATIONS

Note: All installations must contain a pressure relief valve in the discharge line near the pump.

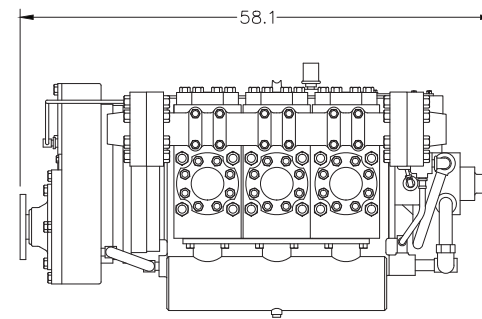
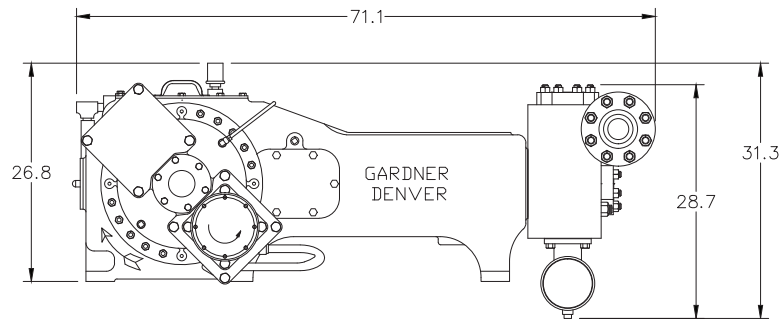

CONNECT WITH US:

www.gardnerdenverpumps.com

1-866-GDPumps

[facebook/GardnerDenverPumps](https://www.facebook.com/GardnerDenverPumps)

[GardnerDenverPumpsTV](https://www.youtube.com/GardnerDenverPumpsTV)

[#pumpingperfected](https://twitter.com/GDPumps)