

# PUMPS



# THUNDER TRIPLEX PUMP

Gardner Denver's Thunder Triplex pump is a workhorse and powerhouse utilizing 2,550 brake horsepower and proven to last 2-3x longer than our competitors with an 11" stroke length and next generation fluid end technology. This pump reduces consumable cost by 50 percent over its lifetime and saves time by delivering unparalleled performance at unprecedented operating efficiencies.

## BEST-IN-CLASS FEATURES

- 11" stroke length reduces consumable cost by 50 percent over the life of the pump
- Reduces downtime with modern design upgrades to improve serviceability in the field
- Proven to last 2-3x longer than other competing pumps
- Next generation fluid end technology showcasing stainless steel construction and innovative geometry to minimize stress
- Utilizes Gardner Denver's innovative Redline Series Consumables to extend fluid end life in the harshest conditions
- 24/7 aftermarket service and support anytime and anywhere you need it



## SPECIFICATIONS

<b>Maximum Input</b>	2,550 BHP (1,902 kW)
<b>Maximum RPM</b>	300 RPM
<b>No. of Cylinders</b>	3
<b>Stroke Length</b>	11 in (279 mm)
<b>Rod Load</b>	275,000 lb (1,223,261 N)
<b>Pump Weight</b>	16,430 lbs (7,453 kg)
<b>Gear Ratio</b>	7.842:1

*(Also available in Quintuplex Version)*

PLUNGER DIAMETER		DISPLACEMENT PER REVOLUTION		DISPLACEMENT AT PUMP RPM - INTERMITTENT SERVICE																			
				50				100				200				250				300			
in	mm	Gallon	m <sup>3</sup>	GPM	m <sup>2</sup> /hr	PSI	bar	GPM	m <sup>2</sup> /hr	PSI	bar	GPM	m <sup>2</sup> /hr	PSI	bar	GPM	m <sup>2</sup> /hr	PSI	bar	GPM	m <sup>2</sup> /hr	PSI	bar
4	102	1.795	0.0068	90	20	20000	1379	180	41	20000	1379	359	82	10956	755	449	102	8765	604	539	122	7304	504
4.5	114	2.272	0.0086	114	26	17291	1192	227	52	17291	1192	454	103	8657	597	568	129	6925	477	682	155	5771	398
5	127	2.805	0.0106	140	32	14006	966	280	64	14006	966	561	127	7012	483	701	159	5609	387	841	191	4675	322
5.5	140	3.394	0.0128	170	39	11575	798	339	77	11575	798	679	154	5795	400	849	193	4636	320	1018	231	3863	266
5.75	146	3.710	0.0140	185	42	10590	730	371	84	10590	730	742	169	5302	366	927	211	4242	292	1113	253	3535	244
6	152	4.039	0.0153	202	46	9726	671	404	92	9726	671	808	183	4869	336	1010	229	3895	269	1212	275	3246	224
6.5	165	4.740	0.0179	237	54	8287	571	474	108	8287	571	948	215	4149	286	1185	269	3319	229	1422	323	2766	191
7	178	5.498	0.208	275	62	7146	493	550	125	7146	493	1100	250	3577	247	1374	312	2862	197	1649	375	2385	164
7.25	184	5.897	0.0223	295	67	6661	459	590	134	6661	459	1179	268	3335	230	1474	335	22668	184	1769	402	2223	153

*Ratings are based on 90% mechanical efficiency and 100% volumetric efficiency*

# THUNDER TRIPLEX PUMP

## STANDARD FEATURES

- 11" stroke length for reduced consumable life cycles and superior flow rate capability when compared to competing pumps
- Balanced crankshaft for reduced operating vibrations
- Falcon twist in spring retainer technology for rapid valve changes with no alignment requirements or special tools
- Optimized fluid end design provides more than 2x life of competing pumps
- Stainless steel fluid end for superior corrosion resistance
- Standard SGWS fluid end internal components
- Plunger, stuffing box and packing nut are Thunder-specific
- Lightweight modular pump design with field-proven GD-3000 planetary gearbox with a 28" offset for mounting flexibility

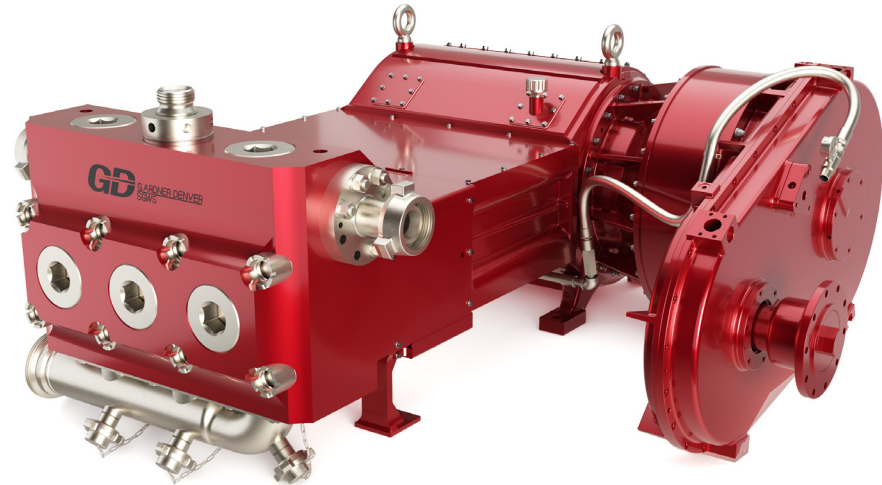

## SPECIFICATIONS

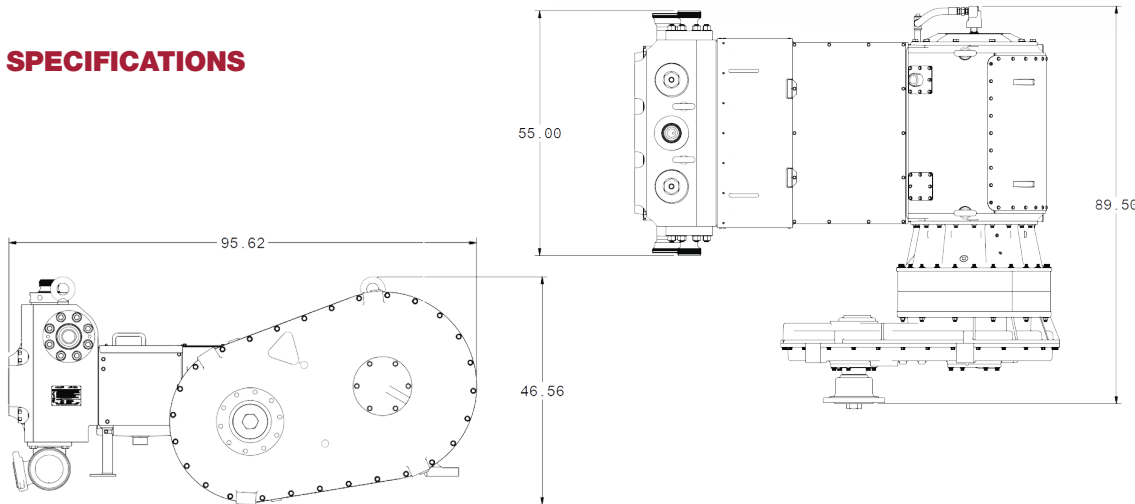

## OPTIONAL FEATURES

- DNV, ABS, PED or other third party certifications
- Splined flange for gear reducer
- Dual discharge flanges
- Various plunger packing styles
- Additional gauge connections
- Hydraulic torque wrench for fluid end removal
- Customizable suction manifolds

## CONNECT WITH US

[www.gardnerdenverpumps.com](http://www.gardnerdenverpumps.com)

1-866-GDPumps | +1-918-GDPumps

 GardnerDenverPumps

 @GDPumps

 GardnerDenverPumpsTV

 GardnerDenverPumps