

TEE **XTREME**

High Pressure Well Servicing Triplex Pump 225 HP, 5" STROKE, 15,000 PSIG DISCHARGE



SPECIFICATIONS:

- Maximum BHP: 225**
- Maximum RPM: 350**
- No. of Plungers: 3**
- Stroke Length: 5 in.**
- Plunger Load: 47,500 lbs.**
- Gear Ratio: 5.61 to 1**
- Oil Capacity: 12 gal.**
- Pump Weight: 4,500 lbs.**

PERFORMANCE RATINGS

Plunger Size		Displacement per Revolution	Displacement at Pump Speed (RPM)												
			Test Rating (10 RPM)				100				150				
in.	mm	GPR	LPR	GPM	LPM	PSI	Kg/cm ²	GPM	LPM	PSI	Kg/cm ²	GPM	LPM	PSI	Kg/cm ²
1.75	44	0.156	0.591	1.6	5.9	16500	1160	16	59	15000	1055	23	88	14500	1019
2.00	51	0.204	0.772	2.0	7.7	15000	1055	20	77	12500	879	31	116	11000	773
2.25	57	0.258	0.977	2.6	9.8	12000	844	26	98	10500	738	39	148	9000	633
2.50	63	0.319	1.206	3.2	12.1	9650	679	32	121	9000	633	48	182	7350	517
2.75	70	0.380	1.463	3.8	14.4	8000	563	38	146	7500	527	57	219	6000	422
Input Power:		BHP	20				180				225				
		KW	15				134				160				

Plunger Size		Displacement per Revolution	Displacement at Pump Speed (RPM)												
			200				275				350				
in.	mm	GPR	LPR	GPM	LPM	PSI	Kg/cm ²	GPM	LPM	PSI	Kg/cm ²	GPM	LPM	PSI	Kg/cm ²
1.75	44	0.156	0.591	31	118	11000	773	43	162	8000	563	55	208	6450	453
2.00	51	0.204	0.772	41	154	8500	598	56	212	6250	439	71	269	4750	334
2.25	57	0.258	0.977	52	195	6500	457	71	269	4800	337	90	341	3850	271
2.50	63	0.319	1.206	64	241	5500	387	88	333	4000	281	112	424	3100	218
2.75	70	0.380	1.463	76	293	4500	316	105	397	3250	228	133	503	2600	182
Input Power:		BHP	225				225				225				
		KW	160				160				160				

Image shows optional planetary gear reducer.

Performance based on 100% volumetric efficiency and 90% mechanical efficiency.
Ratings reflect intermittent duty cycle (30 minute load; 30 minute no load).

NEW - Uprated Performance



119 Nolan Road, Broussard, LA 70518 (337) 837-2701 (800) 535-2934
(337) 837-3250 fax www.candbsales.com sales@candbsales.com

SALES SERVICE PARTS LEASING ENGINEERING PACKAGING

TEE **XTREME**

High Pressure Well Servicing Triplex Pump

Power unit by Gardner Denver, including:

- Eccentric construction
- Left or right gear mounting
- Solid connecting rods
- Clamp-type plunger connections
- Upper and lower crosshead lubrication
- Pressure lubrication of drive train
- Planetary gear reducer (5.6:1 ratio)

Fluid end by C&B, including:

- Forged SAE4330 (modified) cylinder
- Discharge connection on either side
- Removable stuffing boxes with threaded glands
- Hardened-steel, wing-guided valves
- Colmonoy plungers (1.75" to 2.75")
- Non-adjustable, high-performance packing
- Suction connection: 4-inch, 150-lb. Flange
- Discharge connection: 2-inch, 1502 WECO

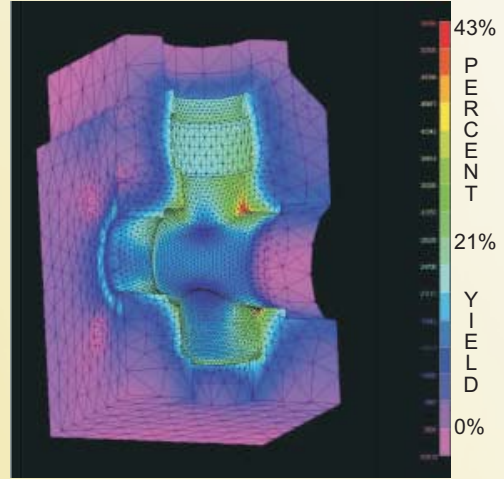

Computer FEA simulation of fluid cylinder

Optional Equipment:

- Dual discharge connections
- Valve cover gauge connection
- Lubricating oil pump, filter, and cooler
- Relief valve and pressure gauge
- Mechanical lubricator for packing
- Stroke counter and flow totalizer
- Pump tools and pullers

Physical Dimensions:

Length 69.8", Width 50.0", Height 26.8"

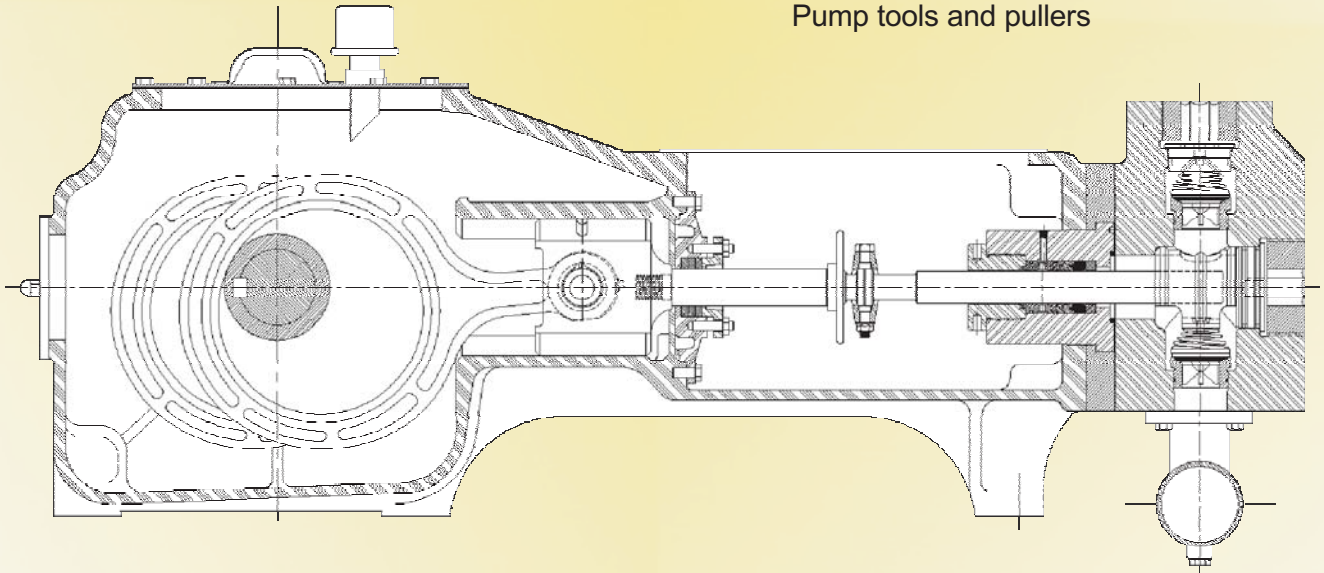

Note: All installations must contain a pressure relief valve on the pump discharge to prevent damage from overpressure.



Your Exclusive Source for the TEE **XTREME**

119 Nolan Road, Broussard, LA 70518 (337) 837-2701 (800) 535-2934
(337) 837-3250 fax www.candbsales.com sales@candbsales.com

SALES SERVICE PARTS LEASING ENGINEERING PACKAGING