

TX-450SB



GARDNER DENVER
WATER JETTING
SYSTEMS, INC.

Pressures to 10,000 PSI
Flows to 105.6 GPM ♦ Power to 450 HP

Fast & Affordable Convertibility

Features:

- ♦ Pressure/flow convertibility from well of pump. Does not require unbolting and retorquing.
- ♦ No valve change required.
- ♦ Inline fluid end design.
- ♦ Pressure range from 7,000 PSI to 10,000 PSI.
- ♦ Flow rates from 27 to 105.6 GPM.
- ♦ Maximum frame load of 30,000 Lbs. / 13608 Kg. for multi-speed, and 25,000 Lbs. / 11340 Kg for single speed.
- ♦ Field proven design.
- ♦ Easy field maintenance.
- ♦ Stainless steel fluid end construction.
- ♦ High volumetric efficiency for maximum horsepower utilization.
- ♦ Rigorously subjected to full load testing.
- ♦ Manufactured on state-of-the-art machinery.
- ♦ Pump attached planetary gear reducer.

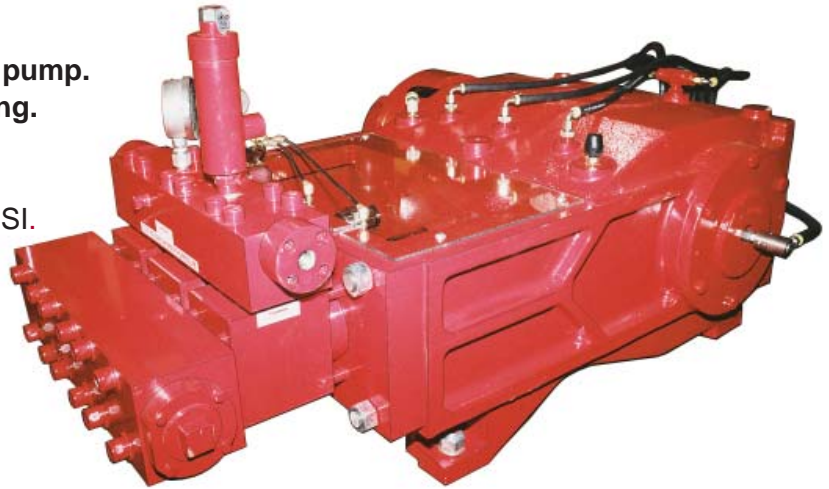

Applications:

- ♦ Water Blasting
- ♦ Concrete Demolition
- ♦ Hydrostatic Testing
- ♦ Water Disposal
- ♦ Industrial Process

Performance Specifications:

	PLUNGER DIA.	MAX. PRESSURE		FLOW					
		PSI	Bar	200 RPM		400 RPM		500 RPM	
				GPM	LPM	GPM	LPM	GPM	LPM
TX-450SB	1.750" - 44mm	10K	690	27.1	106.4	56.2	212.8	70.3	266.0
	1.875" - 48mm	8.8K	607	32.3	122.2	64.6	244.3	80.7	305.4
	2.000" - 51mm	7.8K	538	36.7	139.0	73.4	278.0	91.8	347.5
	2.125" - 54mm	6.8K	469	36.7	139.0	73.4	278.0	103.5	391.7
	2.250" - 57mm	6.1K	420	46.4	175.6	93.0	352.0	113.7	430.3

Note: All flows are based on 100% volumetric efficiency. Pressures shown are based on single-speed performance. See unit specification sheets for pressure ratings on multi-speed units.

Stroke: 4.5" / 114 mm • Max. Speed: 510 RPM • Weight: 4,658 lbs. / 2115 Kg

GARDNER DENVER WATER JETTING SYSTEMS, INC.

Partek • Liqua-Blaster • CRS Power Flow • Jetting Systems • American Water Blaster

1-800-231-3628 ♦ 281-448-5800 ♦ Fax: 281-448-7500

www.waterjetting.com ♦ E-mail: mktg.wjs@gardnerdenver.com



GARDNER DENVER

TX-450SB

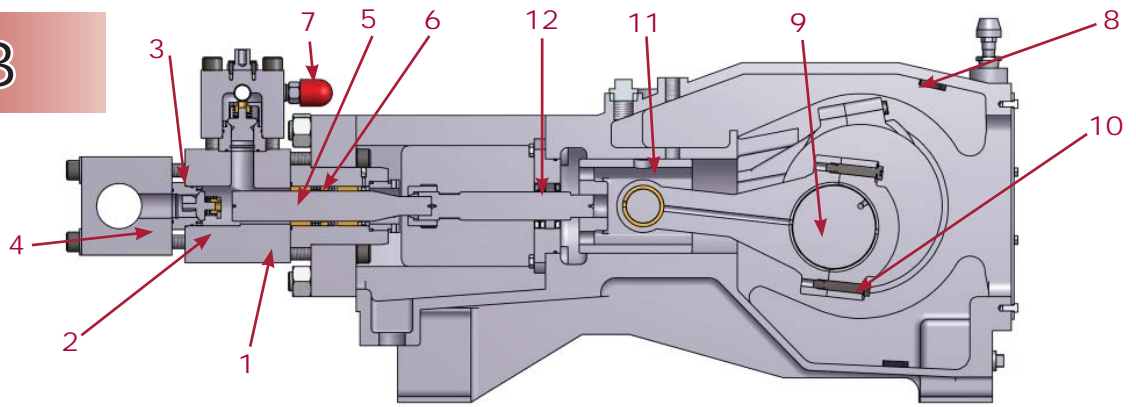

Fluid End

1. Stuffing Boxes: Three boxes machined from hardened stainless steel for extended life.
2. Suction Manifold: Hard, anodized aluminum. Also available in stainless for salt water applications.
3. Valve Assembly: Hardened stainless steel, autofret-taged for extended life. Valves are spring-loaded for positive closing with a common seat used for both suction and discharge valves.
4. Discharge Manifold: Manufactured from precipitation hardened stainless steel.
5. Plungers: Made of stainless steel with colmonoy coating.
6. Plunger Packing: Carbon filled Teflon™ and polyethylene base, spring-loaded, self-adjusting and easily replaceable from the rear of the stuffing box. Force-fed water provides lubrication and cooling.
7. Pressure Relief: Pressure safety head assembly (two rupture discs), mounted to the discharge manifold.

Power End

8. Power Frame: Manufactured from a single piece casting of high strength gray cast iron.
9. Crankshaft: Single extended steel with tapered roller bearings to minimize side thrust load.
10. Connecting Rods: Ductile iron with automotive type split insert bearings.
11. Crossheads: Large, piston type constructed of gray iron.
12. Diaphragm Seals: Installed with o-rings or gaskets and neoprene oil seals.

Reduction Gear: Constructed of top quality AGMA class 12 steel. Hardened and ground gears for strength and durability. Ratios available - 3.35:1, 4.20:1, 4.636:1, 5.21:1.

Forced Oil Lubrication System: Unique pump feature that allows oil to be forced through a rifle-drilled crankshaft lubricating each journal, connecting rod bearings and wrist pin bearings.

Dimensions:

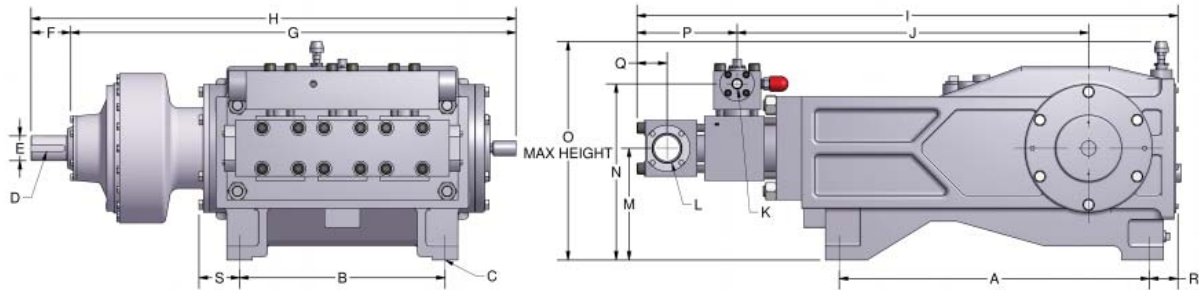

	A	B	C	D	E	F	G	H	I	J	K	L	M	N	O	P	Q	R	S
In.	36 ¹ / ₄	24	1 ⁵ / ₁₆	3/4	2 ⁷ / ₈	4 ⁵ / ₈	52	56 ⁵ / ₈	63 ¹ / ₈	41 ¹ / ₈	1" NPT	3" NPT	13	20 ¹ / ₂	25 ⁷ / ₁₆	11 ³ / ₄	3 ¹ / ₂	3 ⁵ / ₁₆	4 ³ / ₄
mm	921	610	34	19	73	118	1321	1438	1603	1045			330	521	646	299	89	84	121

GARDNER DENVER WATER
JETTING SYSTEMS, INC.
12300 North Houston Rosslyn Road
Houston, TX 77086



www.candbsales.com
119 Nolan Road, Broussard, Louisiana 70518
(337) 837-2701 fax: (337) 837-3250 sales@candbsales.com



GARDNER DENVER WATER JETTING SYSTEMS, INC.

Partek • Liqua-Blaster • CRS Power Flow • Jetting Systems • American Water Blaster

1-800-231-3628 ♦ 281-448-5800 ♦ Fax: 281-448-7500

www.waterjetting.com ♦ E-mail: mktg.wjs@gardnerdenver.com